

HARDI PUMP 503



General specifications

- Compact single diaphragm positive displacement pump.
- Low power consumption.
- Self-priming.
- Can be run dry.
- Can rotate clockwise or anticlockwise.
- Single grease point for lubrication.
- Dry sump to simplify maintenance.
- No special tools needed for maintenance.
- Polyurethane diaphragms and seals.
- Cast iron crankcase and covers.
- 3/4" suction port, 3/4" pressure port.
- Recommended to use HARDI suction and pressure dampers.

503/4.0 (Ref. no. 821618)

- Cylindrical shaft, 25 mm / 0.98".
- For combustion and electric engine use.
- Supplied with narrow base plate.
- Normal operating revolutions, 800 r/min.
- Maximum pressure, 15 bar / 220 PSI.
- Maximum vacuum, 0.82 bar / 12.0 PSI.
- Weight, 9.0 kg / 20 lb.

503/4.0 (Ref. no. 821026)

- Cylindrical shaft, 25 mm / 0.98".
- For combustion and electric engine use.
- Supplied with narrow base plate.
- Normal operating revolutions, 800 r/min.
- Maximum pressure, 25 bar / 367 PSI.
- Maximum vacuum, 0.82 bar / 12.0 PSI.
- Weight, 9.0 kg / 20 lb.

503/7.0 (Ref. no. 821617)

- Tapered shaft.
- For tractor use with HARDI transmission shaft.
- Supplied with wide base plate.
- Normal operating revolutions, 540 r/min.
- Maximum pressure, 15 bar / 220 PSI.
- Maximum vacuum, 0.9 bar / 13.2 PSI
- Weight, 9.2 kg / 20 lb.

503/7.0 (Ref. no. 8216165)

- Tapered shaft.
- With 6-splined coupling for tractor P.T.O. shaft.
- Normal operating revolutions, 540 r/min.
- Maximum pressure, 15 bar / 220 PSI.
- Maximum vacuum, 0.9 bar / 13.2 PSI
- Weight, 10.3 kg / 23 lb.



503 with direct drive unit

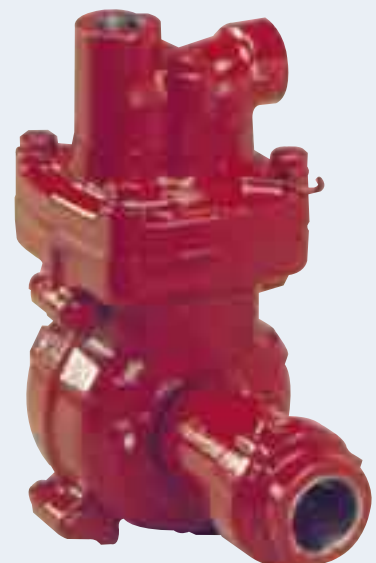

503/7.0 with PTO coupling

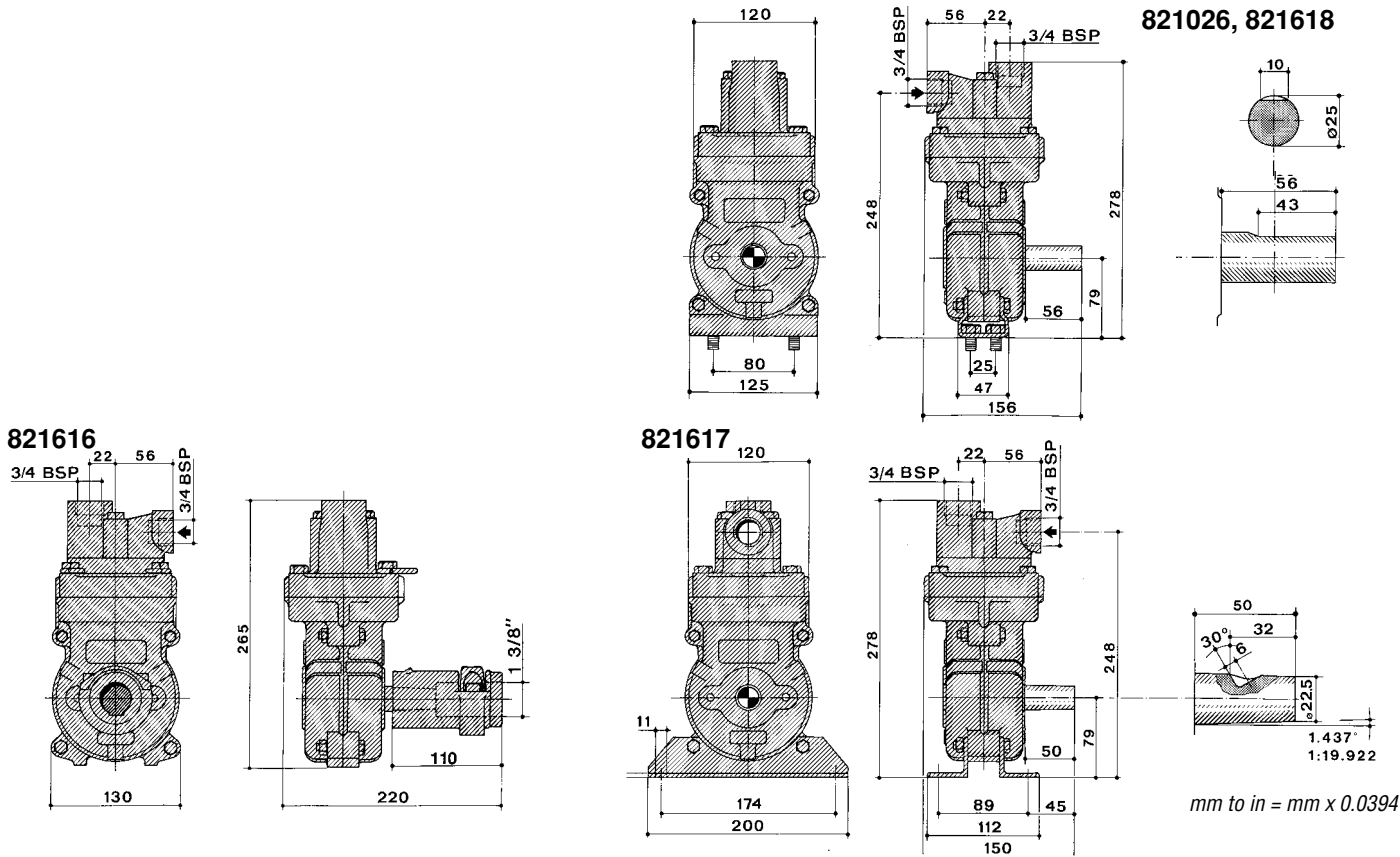

mm to in = mm x 0.0394

	r/min	300		400		500		540		600		700		800		900		1000		
	bar	l/min	kW	l/min	kW	l/min	kW			l/min	kW	l/min	kW	l/min	kW	l/min	kW	l/min	kW	
503/4.0	0	5	0.1	7	0.1	9	0.2			12	0.2	13	0.3	14	0.4	16	0.5	17	0.5	
	2	5	0.1	6	0.2	8	0.2			9	0.3	10	0.4	12	0.5	13	0.5	15	0.6	
	4	4	0.2	6	0.2	7	0.3			9	0.4	10	0.4	12	0.5	13	0.6	14	0.7	
	6	4	0.2	5	0.3	7	0.4			9	0.5	10	0.5	12	0.6	13	0.7	14	0.8	
	10	4	0.2	5	0.3	7	0.5			8	0.6	10	0.7	11	0.7	12	0.8	14	0.9	
	15	4	0.3	5	0.4	7	0.6			8	0.7	9	0.8	11	0.9	12	1.0	13	1.1	
	20	4	0.4	5	0.5	7	0.8			8	0.9	9	1.0	10	1.1	12	1.1	13	1.2	
	25	4	0.5	5	0.6	6	1.0			7	1.1	9	1.2	10	1.3	11	1.3	13	1.4	
		PSI	gpm	hp	gpm	hp	gpm	hp			gpm	hp	gpm	hp	gpm	hp	gpm	hp	gpm	hp
		0	1.3	0.1	1.8	0.1	2.4	0.3			3.2	0.3	3.4	0.4	3.7	0.5	4.2	0.7	4.5	0.7
		29	1.3	0.1	1.6	0.3	2.1	0.3			2.4	0.4	2.6	0.5	3.2	0.7	3.4	0.7	4.0	0.8
		58	1.1	0.3	1.6	0.3	1.8	0.4			2.4	0.5	2.6	0.5	3.2	0.7	3.4	0.8	3.7	0.9
		88	1.1	0.3	1.3	0.4	1.8	0.5			2.4	0.7	2.6	0.7	3.2	0.8	3.4	0.9	3.7	1.1
		147	1.1	0.3	1.3	0.4	1.8	0.7			2.1	0.8	2.6	0.9	2.9	0.9	3.2	1.1	3.7	1.2
	220	1.1	0.4	1.3	0.5	1.8	0.8			2.1	0.9	2.4	1.1	2.9	1.2	3.2	1.3	3.4	1.5	
	294	1.1	0.5	1.3	0.7	1.8	1.1			2.1	1.2	2.4	1.3	2.6	1.5	3.2	1.5	3.4	1.6	
	367	1.1	0.7	1.3	0.8	1.6	1.3			1.8	1.5	2.4	1.6	2.6	1.7	2.9	1.7	3.4	1.9	
503/7.0	0	9	0.1	12	0.2	15	0.3	16	0.3	17	0.4	20	0.4							
	2	8	0.2	11	0.3	14	0.4	15	0.4	16	0.5	19	0.5							
	4	8	0.2	11	0.3	14	0.5	15	0.6	16	0.6	19	0.6							
	6	8	0.3	11	0.4	13	0.7	14	0.8	16	0.8	19	0.8							
	10	8	0.4	10	0.6	13	0.9	14	1.0	16	1.0	19	1.1							
	15	8	0.5	10	0.8	13	1.3	14	1.2	16	1.4	18	1.5							
		PSI	gpm	hp	gpm	hp	gpm	hp	gpm	hp	gpm	hp	gpm	hp						
		0	2.4	0.1	3.2	0.3	4.0	0.4	4.2	0.4	4.5	0.5	5.3	0.5						
		29	2.1	0.3	2.9	0.4	3.7	0.5	4.0	0.5	4.2	0.7	5.0	0.7						
		58	2.1	0.3	2.9	0.4	3.7	0.7	4.0	0.8	4.2	0.8	5.0	0.8						
	88	2.1	0.4	2.9	0.5	3.4	0.9	3.7	1.1	4.2	1.1	5.0	1.1							
	147	2.1	0.5	2.6	0.8	3.4	1.2	3.7	1.3	4.2	1.3	5.0	1.5							
	220	2.1	0.7	2.6	1.1	3.4	1.7	3.7	1.6	4.2	1.9	4.8	2.0							

Model/stroke Pump model and pump stroke in millimetre.
r/min Maximum revolutions per minute is indicated by the highest figure.
Bar / PSI Maximum pressure is indicated by the highest figure.
kW / Hp Power consumption in kilowatt and horsepower.
l/min / gpm Capacity in litres and US gallons per minute at zero suction lift.

HARDI INTERNATIONAL A/S
 HELGESHØJ ALLÉ 38 • DK 2630 TAASTRUP • DENMARK
 E-Mail: hardi@hardi-international.com • www.hardi-international.com